

SOLUTIONS TO STATIC PROBLEMS

GENERATORS EDGE PINNING ON WINDER OR CAST FILM LINE



7080 Bar

Static electricity can be used to “pin” the film to the last steel cylinder before the winder. This will prevent the web from moving laterally from side to side and causing a bad reel.

The same technique is used on cast film lines to prevent the film shrinking (or neck-in) when it touches the chill roller.

There is no need to “pin” the whole web to the cylinder - you only need to pin the edges.

Edge Pinning on a winder

7080 Static Generator Bars, 150mm long. Positioned at each edge of the film at a distance of approximately 20mm from the film.

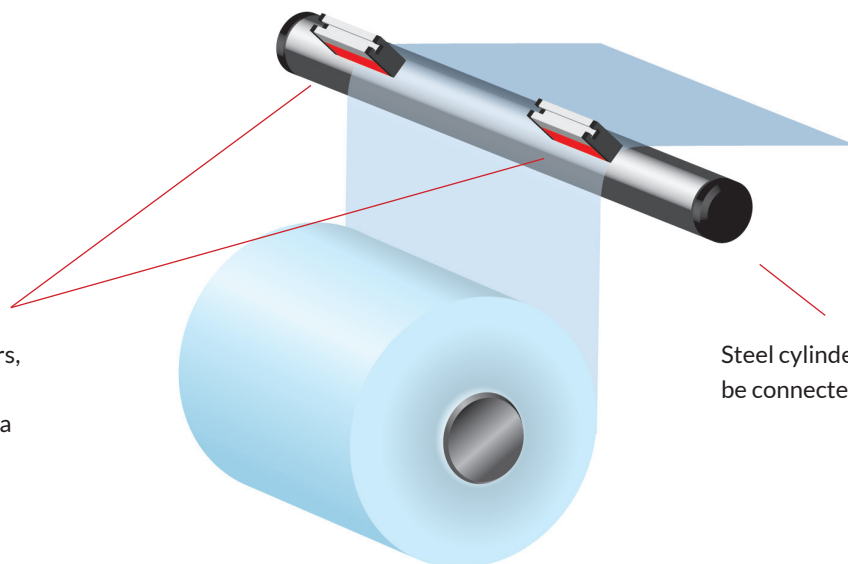

Steel cylinder - it must be connected to earth.

