

SELF-IONISING

101 & 201 STATIC DISCHARGERS

Fraser Static Dischargers offer high performance with unrivalled cost-effectiveness and versatility. They are particularly effective for high speeds and high charges.

Fraser static dischargers are highly efficient anti-static tools which are used on countless machines processing sheets and webs.

- > They are available in two versions: Models 101 and 201, giving a choice of body, fibre and fibre length - see next page for details.
- > The Model 101 is available in lengths up to 4m. Model 201 is available in lengths up to 3m.
- > For ATEX / Hazardous area applications, see EX-HPSD Static Dischargers.



Specification

Length:	Model 101 - Any length up to 4m. Model 201 - Any length up to 3m.
Construction:	Model 101 - has robust 2mm extruded body. Mounting holes may be drilled in the "h" single wall. Model 201 - 9.5mm x 9.5mm aluminium body. Mounting studs M4 x 10mm, 10mm from each end and in centre for lengths over 1m.
Fibres:	Carbon Fibre: 6/7 μ diameter. 60,000 filaments per cm. Nylon Fibre: 35 μ diameter. 4-5,000 filaments per cm.

How it works:

The “brushes” have a large number of highly conductive fibres. The fine tips of the fibres concentrate the electric field of the static charge and ionise the air. This ionised air provides ions of the opposite polarity to neutralise the static charge and allow it to flow to earth through the brush body. The tips of the fibre do not need to touch the material to be neutralised, normally they are positioned 2-3mm from it. The Static Discharger body must be connected to an earth/ ground.

Dimensions

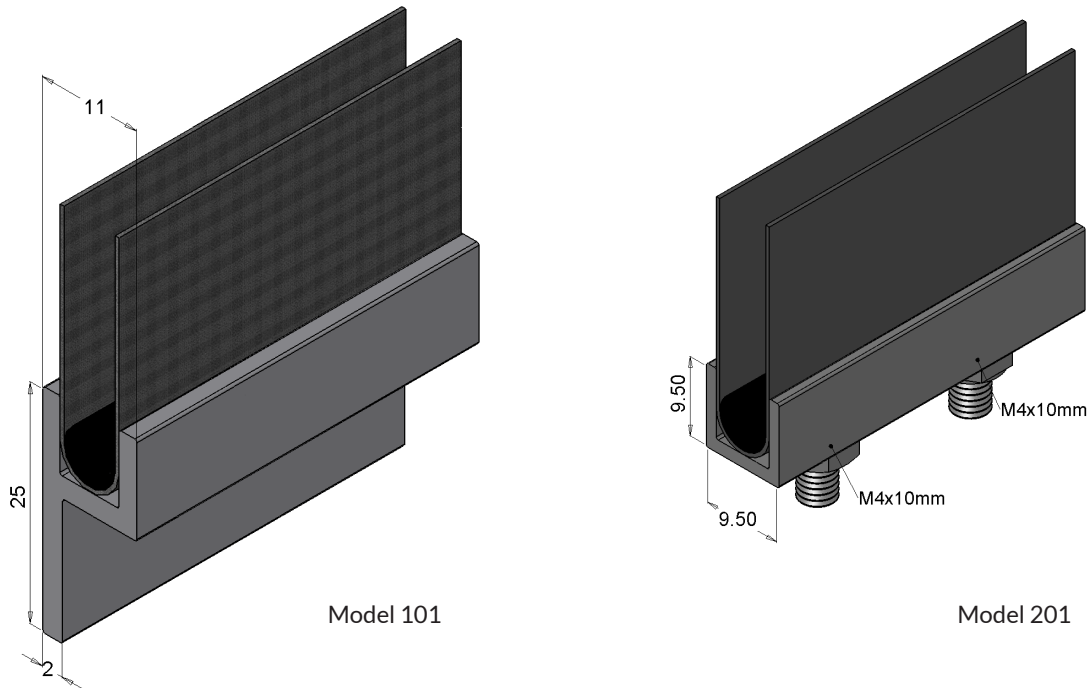

Options

Choice of Fibre:

Carbon or Conductive Nylon? Carbon fibre is more effective and lower in cost. It is suitable for 90% of applications.

Nylon fibre has more resilience and can be washed in water to clean out dust and other contaminants.

For standard applications we recommend carbon fibre; for “clean” applications we recommend nylon.

Fibre length:

In addition to the choice of carbon or nylon fibre, there is a choice of fibre length. 18mm is standard and suitable for most applications. We can also supply 30mm, 50mm and 80mm fibre lengths.

ATEX/Hazardous Area applications:

See EX-HPSD Static Dischargers.

ATEX Certified Static Dischargers with solvent resistant construction available in lengths up to 4m.