

ANTI-STATIC BARS

1250 & 1250-S STATIC ELIMINATORS

Powerful performance and market-leading reliability make the 1250 and 1250-S the first choice static eliminators for manufacturers.

The 1250 and 1250-S neutralise static electricity on sheet, web and similar processes throughout the plastics, packaging, converting and related industries.

- > The modern design gives high performance and completely shockless operation.
- > Stay-sharp etched emitters for better long term performance.
- > Emitters at 10mm pitch provide the most intense field of static neutralisation.
- > All electronic components are fully encapsulated for maximum reliability.
- > They are suitable for food, medical, pharmaceutical and many cleanroom applications.
- > Robust construction ensures a long life of high performance.
- > Simple to install - with fixed mounting studs (1250) or studs sliding in slot (1250-S).
- > Operating distances of up to 150mm, best distance 20 - 50mm.
- > Washable and easy to clean.



Specification

Length:	From 60mm to 6m.
Construction:	Anodised aluminium, epoxy resin, PVC and hardened etched emitters.
Cable:	Hi-Flex PVC, 30kV screened cable with 70mm bend radius. Standard length is 2m - longer lengths can be specified at time of order, (subject to maximum load on power unit), 90° cable exit option. Bars may be supplied in series - joined by cable.
Power Unit:	Use with Fraser 5.5kV & 6kV Power Units - see datasheets.
Safety:	5mA maximum current from Power Unit. High voltage resistance inside bars further limits current below 50µA.
Mounting:	See sketches to show 1250 and 1250-S options. 200mm x 20mm steel fixing strips are supplied with each bar.
Environment:	60° maximum temperature. 70% rH non-condensing max.
Standards:	CE. UL (US and C) Listing is a free of charge option.

How it works

The 1250 works by applying high voltage to an emitter in a controlled and safe way. The electric field around the emitters ionises the air - breaking it up into positive and negative ions. These ions neutralise static electricity by being attracted to charges of the opposite polarity. Unused ions quickly dissipate into the atmosphere.

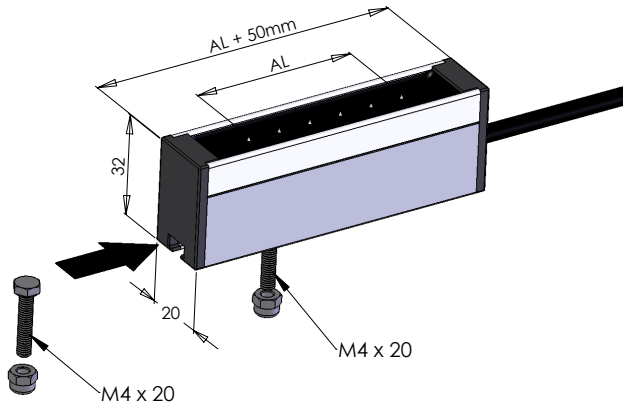

1250-S

The 1250-S has M4 x 20mm hexagon head mounting studs which slide in a groove on the underside of the bar. This gives fast and simple installation.

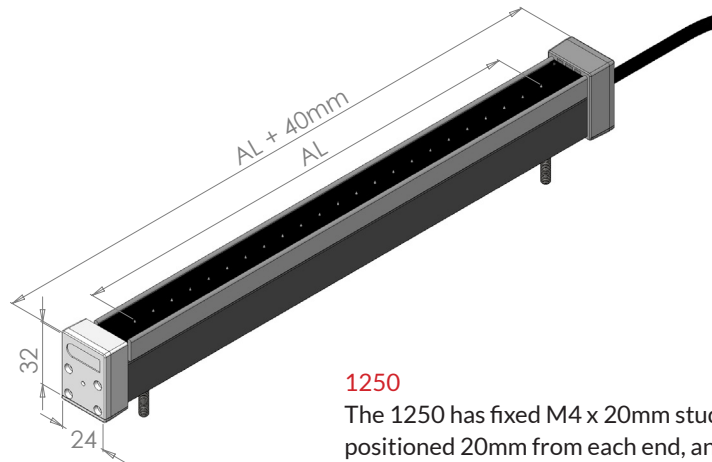

1250

The 1250 has fixed M4 x 20mm studs positioned 20mm from each end, and in the middle for longer bars.

Variants

- EX - ATEX:** For hazardous areas see EX-1250 datasheet.
- Airboost:** For extending the range up to 500mm, see 1250-AB Datasheet.
- Balanced:** For high tech applications where an accurate electrical ion balance is required.
- High Charge:** See Super 80 datasheet - considered by many to be the most powerful static eliminator bar of its type available.
- Combination:** A passive static discharger may be combined with a 1250, for speeds over 1000m/min.
- Series:** Bars supplied in series - joined by cable.